



---

# EcoMesh Controller

## (EcoMesh)

# Instruction Manual

### Contents

Introduction.....	2
Block diagram.....	2
Description.....	3
Power supply .....	3
Sensor input .....	3
External override input .....	3
Control output.....	3
User interface.....	3
Installation.....	4
Connection diagram.....	4
Internal layout diagram.....	5
Dimensional drawing.....	6
Mode of operation .....	6
Technical Specification .....	8
Ordering information.....	9
Supplier information.....	9

Copyright (C) 2000-2 Environmental Process Systems Controls Limited

This document contains proprietary information which is protected by copyright. All rights reserved. This document or parts thereof may not be reproduced in any form without written permission of the publishers.

The information in this document is subject to change without notice and should not be construed as a commitment by Environmental Process Systems Limited. shall not be liable for errors contained herein or for incidental or consequential damages in connection with the furnishing, performance or use of this material.

## Introduction

This instruction manual describes a dedicated temperature and time controller used to control the water spray to a cooling mesh for an evaporative cooling system.

When the measured temperature is between the low and high setpoint temperature, the output will cycle between the minimum and maximum output settings.

There is also a temperature independent output cycle to provide a periodic output regardless of the measured temperature.

The timer control output is a solid state triac output.

External Override - an external override in the form of volt-free contact input can be used to force the controller into maximum output.

All user adjustments are by means of front panel push buttons with indication of setting and measurement by 7-segment LED display.

## Block diagram

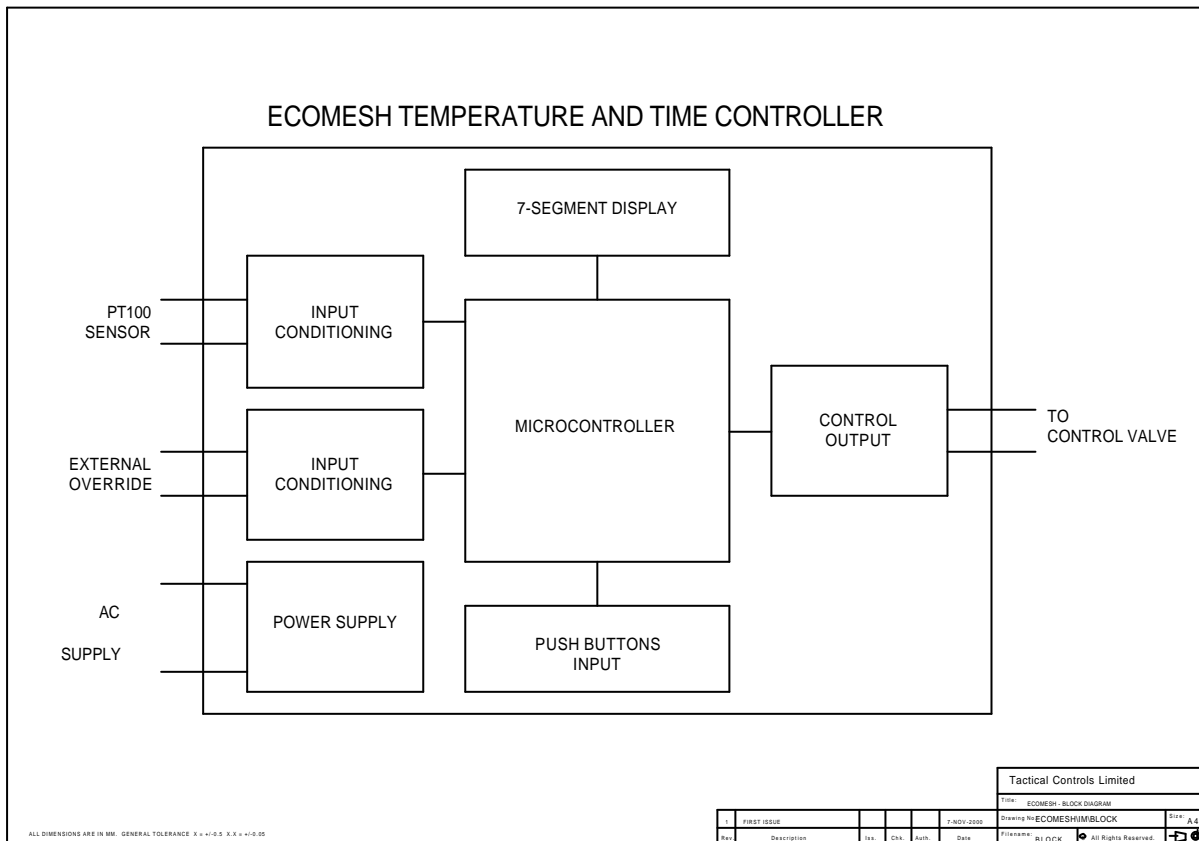

## Description

The operator panel consists of two Printed Circuit Boards (PCB) which house the power supply, sensor input conditioning circuitry, microcontroller, 7-segment Light Emitting Diode (LED) display for temperature and timer indication, status indicating LED, control and setting push buttons, and output circuitry.

The PCB is mounted inside a plastic enclosure. Both the display and the push buttons are protected by the transparent cover.

All the connections to the controller are via plug-in screw terminals.

## Power supply

The control panel requires 110 or 240Vac 5VA max. 50/60Hz supply. Please specify the supply voltage when order.

## Sensor input

A platinum resistance thermometer PT100 temperature sensor is supplied as standard.

## External override input

An optional volt-free contact can be connected to the external override input to force the controller output to maximum when the contact is closed.

## Control output

Opto-triac outputs are used for the control output. The rating is 240Vac 1A max.

## User interface

The user interface comprises of 3 digits 7-segment green LED display, 1 status indicating LED and 3 push buttons.

The 7-segment display is used to indicate measured temperature, low setpoint temperature, high setpoint temperature, and 3 sets of ON time setting and OFF time setting.

One red LED is used to show the output status of the controller.

One push button is used to scroll the parameter display. The two adjustment push buttons "UP" and "DOWN" enable the temperature and time setting to be incremented and decremented.

Please note the display will revert to showing measured temperature after 1 minute of inactivity on the push buttons.

## Installation

The EcoMesh controller can be wall mounted using the mounting kit provided. Please see dimensional drawing for fixing holes arrangement.

All the electrical connections are via plug-in screw terminals. There are 4 sets of connections:

The sensor input (PRT100 sensor) is connected to a 2 way connector IN+ and IN- of the RT input on the PCB. The sensor is not polarity sensitive.

The optional external override input (volt-free contact) is connected to a 2 way connector OVR+ and OVR- on the PCB. The external override input is not polarity sensitive.

The controller output is connected to a 2 way connector LINE and LOAD of the OUTPUT 1 on the PCB. Please note from release 2.1 onwards, the LINE and LOAD should connect directly to the external solenoid valve.

The mains supply is connected to a 2 way connector L and N of the mains input on the PCB.

## Connection diagram

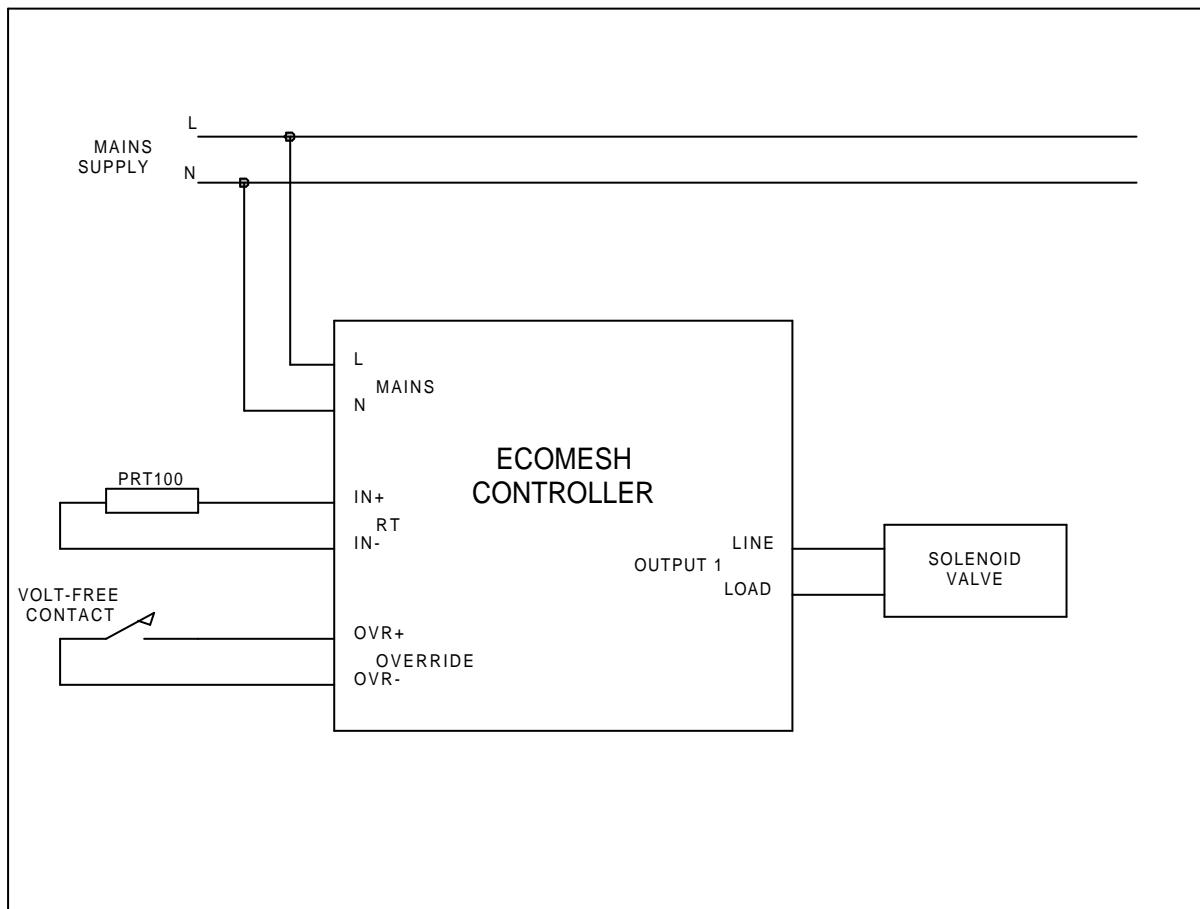

**Internal layout diagram (user interface)**

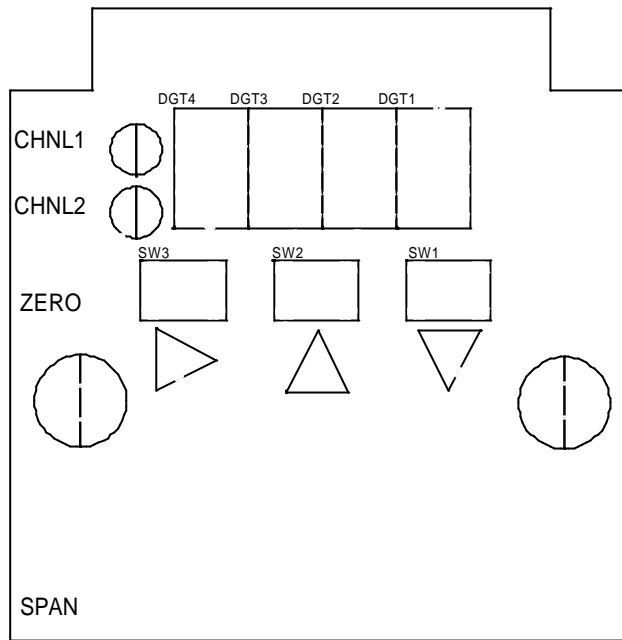

**Internal layout diagram (input/output)**

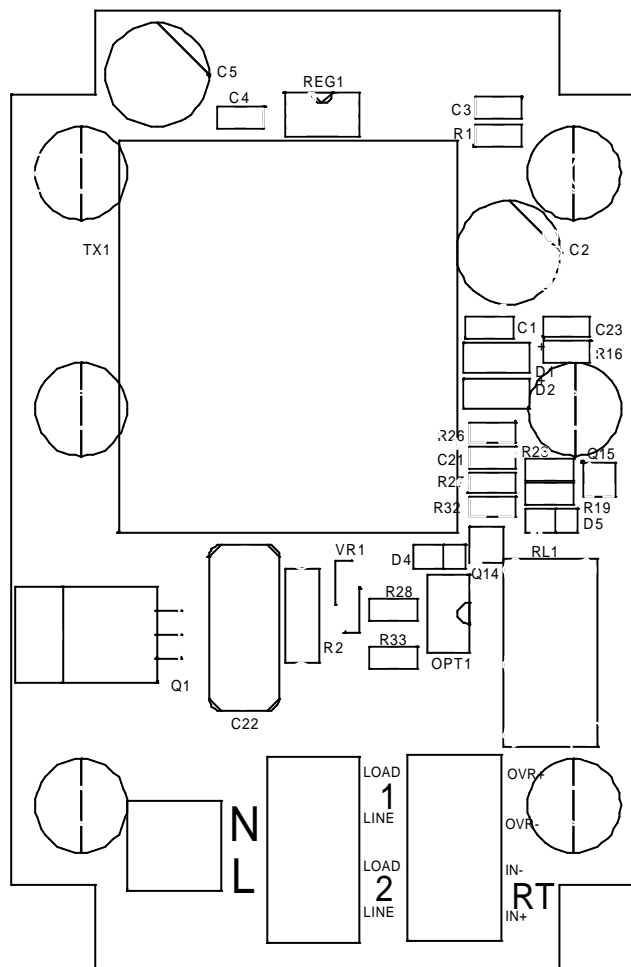

**Dimensional drawing**

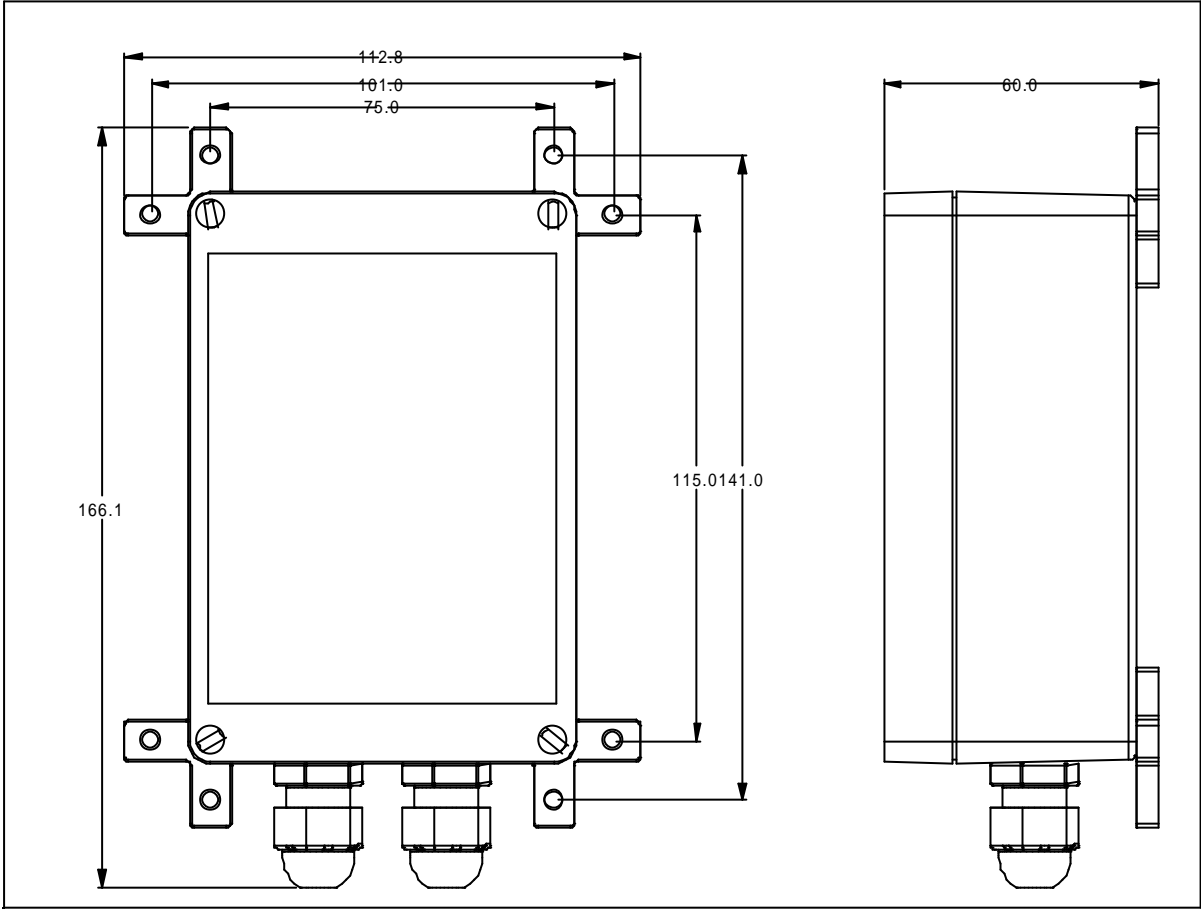

## Mode of operation

All the parameters in the EcoMesh controller can be accessed by pressing the scroll button. Apart from the measured temperature, all the parameters can be set within their limits using the UP and DOWN button.

The following are the list of parameters:

Symbol	Description	Low limit	High limit	Default	Unit
t	Measured temperature	0	99		°C
L	Low Setpoint	10	60	20	°C
H	High Setpoint	10	60	40	°C
1	T1 minimum ON time	1	99	2	Second
2	T2 minimum OFF time	0.5	99	2	Minute
3	T3 maximum ON time	1	99	10	Second
4	T4 maximum OFF time	0.5	99	1	Minute
5	T5 Cycle OFF time	0	99	0	Hours
6	T6 Cycle ON time	0	99	0	Second

The EcoMesh controller is designed such that when the measured temperature is equal to the lower setpoint temperature, the output is enabled with the minimum output cycle as specified by T1 and T2. When the measured temperature reaches the high setpoint temperature, the output is enabled with the maximum output cycle as specified by T3 and T4. When the measure temperature is between the low setpoint and high setpoint temperature, the output is enable with the same proportion between the minimum and maximum output cycle.

The temperature range is between 0°C to 99°C. The temperature input is from a PT100 Platinum resistance sensor. The temperature control output enables the internal timer control.

The timer control range is between 1 to 99 seconds in steps of 1 second for the ON period, and 0.5 to 10 minutes in steps of 1 minute with finer adjustment of 0.5 minute between 0.5 to 10 minutes for the OFF period.

There is also a temperature independent output cycle which is governed by T5 and T6. This can be switched OFF by setting either the ON time or OFF time or both to zero. The timer range is 0 to 99 seconds in steps of 1 second for the ON period and 0 to 99 hours in steps of 1 hour for the OFF period.

**Technical specification**

Sensor input	PT100
Control Setpoint	0 to 99 °C in step of 1 degree
Temperature Control	ON/OFF with 1°C hysteresis Low temperature setting 0 to 99 °C High temperature setting 0 to 99 °C
Timer Control	Min/Max ON: 1 to 99 seconds in steps of 1 second and Min/Max OFF: 0.5 to 10 minutes in steps of 0.5 minute 10 to 99 minutes in steps of 1 minute Cycle ON: 0 to 99 seconds in steps of 1 second Cycle OFF: 0 to 99 hours in steps of 1 hour
Control Output	Triac 1A max. 240Vac
External override	External volt-free contact Close contact force maximum output
Display	Three 7-segment LED green for temperature, ON timer and OFF timer
Push buttons	3 positive feedback tactile push buttons
Connection	Plug-in screw terminals 2 for supply 2 for control output 2 for external override input 2 for sensor input
Supply	110/230 Vrms +/-15% 50/60Hz 5VA max. (specified voltage when order)
Dimensions	166mm(L) x 115mm(W) x 60mm(H) max.
Mounting positions	Fixing centres 115mm x 101mm; and 141mm x 75mm; mounting kit provided.
Weight	500g max.
Temperature	0 to 50 °C operating; -20 to 65 °C storage
<b>Warranty</b>	12 months return to base

## **Ordering information**

Ordering code: EcoMesh-vvv-00

where vvv is either 110 or 230

You are welcome to order the unit by code or description - EcoMesh Time and Temperature controller.

For example, EcoMesh-230-00 is an EcoMesh Time and Temperature controller with 230V supply voltage.

## **Supplier information**

### **Environmental Process Systems Controls Limited**

Unit 32,  
Mere View Industrial Estate,  
Yaxley, Cambridgeshire,  
PE7 3HS, United Kingdom  
Tel: +44-(0)-1733 243400  
Fax:+44-(0)-1733 243344  
Email : sales @epsLtd.co.uk

**[www.epsLtd.co.uk](http://www.epsLtd.co.uk)**