

**301ss**

**STAINLESS STEEL BALL VALVE  
3 PIECE FULL BORE LOCKABLE,  
BSP, BSPT, NPT, SOCKET/BUTT-WELD**

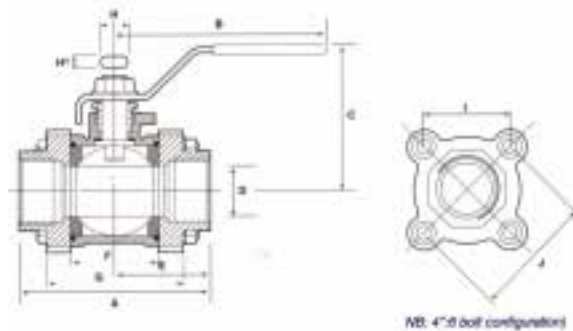

MATERIALS	
<b>BODY</b>	Cast Stainless Steel CF8M
<b>BALL</b>	316 Stainless Steel Precision Machined and Mirror Finished
<b>SPINDLE</b>	316 Stainless Steel
<b>SEAT/SEALS</b>	RPTFE (MG 1241)
<b>O-RING</b>	RPTFE (MG 1241)
<b>HANDLE</b>	Stainless Steel 304 c/w Thermo Insulating Sleeve



**OPTION:** Can be supplied Silicon Free

DIMENSIONS AND SPECIFICATIONS																
SIZE	A	B	C	D	E	F	G	H	H*	I	J	WEIGHT KG	PRESSURE PN	TEMP - °C +	TORQUE in Nm	FLOW Kv
1/8																
1/4	60.0	96.0	57.0	11.6	30.0	21.3	35.3	9.6	6.0	34.5	39.3	0.380	69	-20 > 200	7.12	6.88
3/8	60.0	96.0	57.0	12.7	30.0	21.3	35.3	9.6	6.0	34.5	39.3	0.380	69	-20 > 200	7.12	8.60
1/2	75.0	124.0	68.0	15.9	37.5	26.5	44.5	11.2	6.3	42.0	48.5	0.675	69	-20 > 200	8.54	12.90
3/4	80.0	124.0	70.0	20.6	40.0	33.0	51.0	11.2	6.3	46.5	55.5	0.860	69	-20 > 200	12.81	27.52
1	90.0	142.0	80.0	25.4	45.0	37.2	55.6	11.2	8.0	52.1	61.0	1.300	69	-20 > 200	19.93	38.70
1 1/4	110.0	142.0	84.0	31.8	55.0	46.6	67.6	11.2	8.0	63.7	75.5	2.100	69	-20 > 200	31.32	70.52
1 1/2	120.0	202.0	93.0	38.1	60.0	55.0	77.0	11.2	9.5	74.0	88.0	2.780	69	-20 > 200	37.02	103.20
2	140.0	202.0	100.0	50.8	70.0	69.6	95.0	11.2	9.5	88.1	108.0	4.430	69	-20 > 200	45.56	206.40
2 1/2	185.0	250.0	142.0	65.0	92.5	85.4	116.4	19.1	12.0	94.2	133.2	7.900	69	-20 > 200	91.12	275.20
3	205.0	250.0	155.0	80.0	102.5	98.5	132.5	19.1	12.0	111.7	158.0	12.800	69	-20 > 200	136.68	516.00
4	240.0	300.0	172	100.0	120.0	130.2	165.2	19.1	15.0	166.0	190.0	22.500	69	-20 > 200	199.33	774.00
5																
6																
8																

Pressure rating dependent upon temperature. Figures shown are maximum examples only.  
Information correct at the time of going to press. We reserve the right to alter specifications without notice.



**Unit 32, Mere View Industrial Estate, Yaxley, Cambridgeshire, PE7 3HS, UK**

**Tel: +44 (0) 1733 243400, Fax: +44 (0) 1733 243344, e-mail: info@epsLtd.co.uk, www.epsLtd.co.uk**