

# 216F

## 2 PIECE FULL BORE STAINLESS/CARBON STEEL FLANGED BALL VALVE - PN16-F4

MATERIALS	
BODY	ASTM A351-CF8M / A216-WCB
CAP	ASTM A351-CF8M / A216-WCB
BALL	ASTM A351-CF8M / A351-CF8
SEAT	PTFE (RTFE)
BODY SEAL	PTFE
THRUST BEARING	PTFE
STEM PACKING	PTFE
STEM	ASTM A276-316 / A276-304
GLAND RING	ASTM A276-316 / A276-304
STUD	ASTM A193-B8 / A193-B7
NUT	ASTM A194-8A / A194-2H
STEM NUT	ASTM A194-8A / A194-2H
STOP BOLT	ASTM A193-B8 / A193-B7
HANDLE	ASTM A536
HANDLE BOLT & WASHER	ASTM A36
ANTI STATIC	AISI 316
BELLEVILLE DISC	SS301 Stainless Steel

SPECIFICATION	
FLANGE DIMENSIONS	DIN2633-PN16

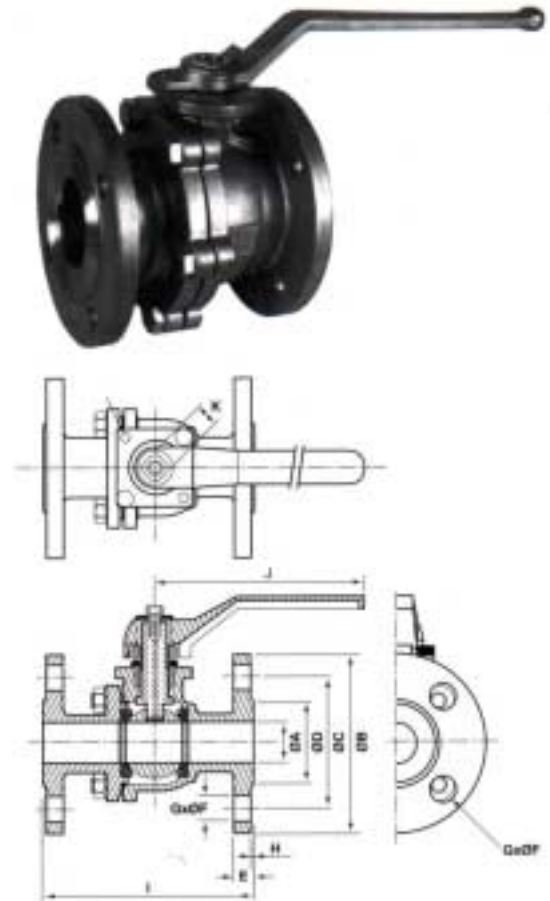

NB: F4 length only available up to 4", 5" > 12" F5 Dimensions are used

### DIMENSIONS AND SPECIFICATIONS

SIZE	A	B	C	D	E	F	G	H	I F4	J	K	PRESSURE PN	WEIGHT KG	TORQUE in Nm	ISO-5211
1/2	15.0	95.0	65.0	45.0	14.0	14.0	4.0	2.0	115.0	130.0	11.0	16	2.5	3.0	42xM5xP0.8
3/4	20.0	105.0	75.0	58.0	16.0	14.0	4.0	2.0	120.0	130.0	11.0	16	3.5	6.0	42xM5xP0.8
1	25.0	115.0	85.0	68.0	16.0	14.0	4.0	2.0	125.0	225.0	13.7	16	4.5	9.5	50xM6xP1.0
1 1/4	32.0	140.0	100.0	78.0	16.0	18.0	4.0	2.0	130.0	225.0	13.7	16	6.0	10.5	50xM6xP1.0
1 1/2	40.0	150.0	110.0	88.0	16.0	18.0	4.0	3.0	140.0	225.0	13.7	16	7.0	14.0	50xM6xP1.0
2	50.0	165.0	125.0	102.0	18.0	18.0	4.0	3.0	150.0	333.0	16.7	16	10.0	35.0	70xM8xP1.25
2 1/2	65.0	185.0	145.0	122.0	18.0	18.0	4.0	3.0	170.0	333.0	16.7	16	14.5	55.0	70xM8xP1.25
3	80.0	200.0	160.0	138.0	20.0	18.0	8.0	3.0	180.0	395.0	21.7	16	19.0	80.0	102xM10xP1.5
4	100.0	220.0	180.0	158.0	20.0	18.0	8.0	3.0	190.0	395.0	21.7	16	32.0	120.0	102xM10xP1.5
5	125.0	250.0	210.0	188.0	22.0	18.0	8.0	3.0	325.0	600.0	26.0	16	50.0	136.0	125xM12xP1.75
6	150.0	285.0	240.0	212.0	22.0	22.0	8.0	3.0	350.0	800.0	26.0	16	72.0	396.0	125xM12xP1.75
8	200.0	340.0	295.0	268.0	24.0	22.0	12.0	3.0	400.0	1100.0	32.0	16	150.0	770.0	125xM16xP1.75
10	250.0	405.0	355.0	320.0	26.0	26.0	12.0	3.0	450.0	1100.0	32.0	16	210.0	1350.0	140xMxP2.0
12	300.0	460.0	410.0	378.0	26.0	26.0	12.0	4.0	500.0	1100.0	32.0	16	300.0	2500.0	140xMxP2.0
16															

Pressure rating dependent upon temperature. Figures shown are maximum examples only.  
Information correct at the time of going to press. We reserve the right to alter specifications without notice.



Unit 32, Mere View Industrial Estate, Yaxley, Cambridgeshire, PE7 3HS, UK

Tel: +44 (0) 1733 243400, Fax: +44 (0) 1733 243344, e-mail: info@epsLtd.co.uk, www.epsLtd.co.uk