

# 200W

# CAST IRON WAFFER PATTERN BUTTERFLY VALVE

MATERIALS	
BODY	Cast Iron
DISC	Aluminium Bronze
SEAT	Buna-N or EPDM
SHAFT	SS316 Stainless Steel
TAPER PIN	SS316 Stainless Steel
O-RING	Buna-N or EPDM
BUSHING	Teflon
OPTION	
BODY	Ductile Iron
DISC	SS316 Stainless Steel
SEAT	PTFE on EPDM VITON®
TEMPERATURE RANGE °C	
BUNA	-15 > 90
EPDM	-35 > 135
PTFE	-50 > 200
VITON®	-15 > 135
FLANGED DRILLING	

Universal Body Drilling to suit PN 10/16 (P)  
ANSI 150 (P1) and BS10 Table E (P2)

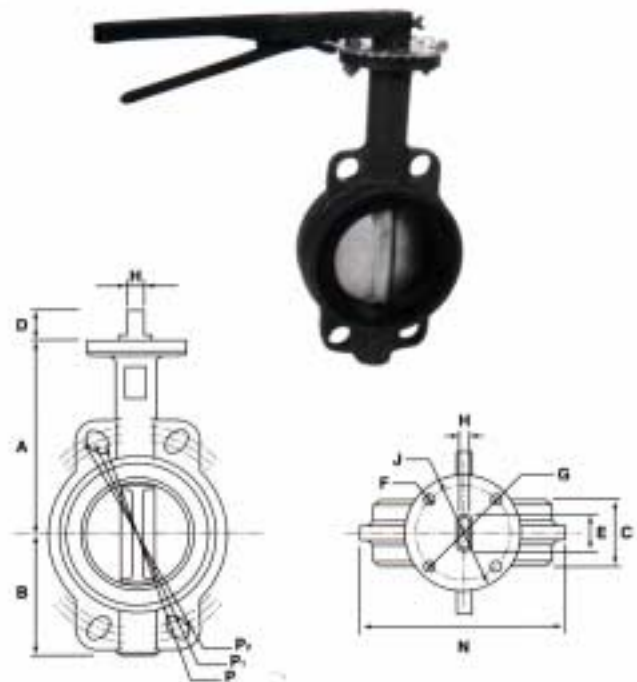

## DIMENSIONS AND SPECIFICATIONS

SIZE	DN	A	B	C	D	E	F	G	H	J	N	P PN10/16	P1 ANSI 150	P2 TAB E	WEIGHT KG	PRESSURE PN
1½												110.0	98.0	98.0		
2	50	162.0	83.0	44.0	32.0	12.6	9.5	70.0	10.0	90.0	101.6	125.0	121.0	114.0	2.72	16
2½	65	175.0	95.0	48.0	32.0	12.6	9.5	70.0	10.0	90.0	120.7	145.0	140.0	127.0	3.18	16
3	80	181.0	102.0	48.0	32.0	12.6	9.5	70.0	10.0	90.0	130.2	160.0	152.0	146.0	4.54	16
4	100	200.0	124.0	54.0	32.0	15.8	9.5	70.0	12.0	90.0	171.5	180.0	191.0	178.0	5.90	16
5	125	213.0	137.0	57.0	32.0	18.9	9.5	70.0	14.0	90.0	196.9	210.0	216.0	210.0	8.16	16
6	150	225.0	149.0	57.0	32.0	18.9	9.5	70.0	14.0	90.0	219.1	240.0	241.0	235.0	9.07	16
8	200	260.0	181.0	64.0	45.0	22.1	14.3	100.0	17.0	150.0	268.3	295.0	298.0	292.0	14.51	16
10	250	292.0	210.0	70.0	45.0	28.5	14.3	100.0	22.0	150.0	331.8	355.0	362.0	356.0	19.05	16
12	300	337.0	248.0	79.0	45.0	31.6	14.3	100.0	24.0	150.0	406.4	410.0	432.0	406.0	31.75	16
14	350	368.0	279.0	79.0	45.0	31.6	14.3	140.0	24.0	150.0	435.0	470.0	476.0	470.0	43.09	16
16	400	400.0	305.0	89.0	50.0	33.2	20.65	140.0	27.0	150.0	508.0	525.0	540.0	521.0	53.07	16
18	450	422.0	365.0	108.0	50.0	38.0	20.65	165.0	27.0	210.0	542.9	585.0	578.0	584.0	74.84	10
20	500	480.0	371.0	134.0	64.0	44.1	20.65	165.0	32.0	210.0	592.1	650.0	635.0	641.0	124.74	10
24	600	562.0	457.0	156.0	70.0	50.6	20.65	165.0	36.0	210.0	708.1	770.0	749.0	756.0	199.58	10

Pressure rating dependent upon temperature. Figures shown are maximum examples only.  
Information correct at the time of going to press. We reserve the right to alter specifications without notice.



Unit 32, Mere View Industrial Estate, Yaxley, Cambridgeshire, PE7 3HS, UK

Tel: +44 (0) 1733 243400, Fax: +44 (0) 1733 243344, e-mail: info@epsLtd.co.uk, www.epsLtd.co.uk